

# E-PBD-SO50

## Miniature Single Photobeam

### Manual

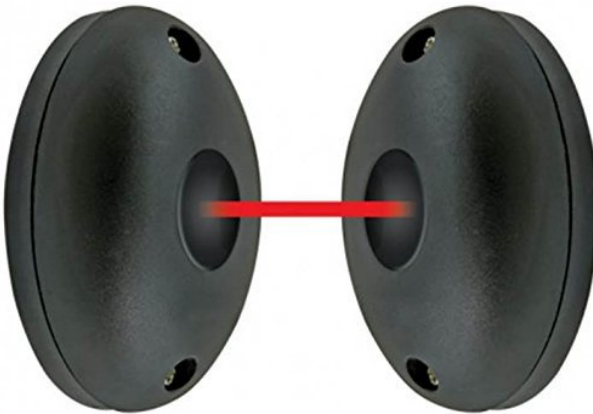

- Small size for a less conspicuous installation
  - Simple to install
  - Built-in AGC control to filter out lighting disturbances
  - Signal strength indicator for easier alignment
  - LED indicators for power, signal strength, and alarm
  - Weatherproof for outdoor as well as indoor use (IP65)
  - Mounting hardware included
-

## Introduction:

The E-PBD-SO50 is a simple, easy-to-use, and easy-to-install single-beam infrared motion sensor. The device easily installs almost anywhere to provide an invisible beam that, when broken, sends a signal to activate a light, beeper, or other device. This makes the device perfect for use as part of an access control system, a door or window monitor, a retail store customer alert, or many other places where the user needs to know that someone has entered a specific room or other protected area. The sensor is weather-proof, and comes with a built-in AGC control circuit that helps to filter out possible disturbance caused by local lighting conditions.

## Parts List:

1x Transmitter	6x Screws	1x Manual
1x Receiver	6x Plastic wall anchors	

## Specifications:

Number of beam channels		Single infrared beam
Number of beam frequencies		1
Sensor range		3~50ft (1~15m)
Infrared LED wavelength		940nm
LED beam spread angle		Approximately $\pm 10^\circ$
Interrupt speed*		50ms
Input power		10~24VDC
Current draw (max)	Transmitter	15mA@12VDC
	Receiver	30mA@12VDC
Relay output		NO/NC relay (set by jumper, default is N.C.) 0.5A@30VAC/VDC
LED (Transmitter)		Green - Indicates connected to power
LEDs (Receiver)	Power (Green)	Indicates connected to power
	Signal (Yellow)	Indicates receiver's signal is weak or beam is broken
	Alarm (Red)	Indicates transmitter and receiver are not aligned or beam is broken
IP rating		IP65
Operating Temperature		-13~131°F (-25~55°C) maximum humidity 95%
Dimensions		3"x1 <sup>15</sup> / <sub>16</sub> "x1 <sup>3</sup> / <sub>16</sub> " (76x48x30 mm)
Weight		1.2-oz (34g)

\*This is the minimum time interval for breaking the beam which will trigger the output.

## Overview:

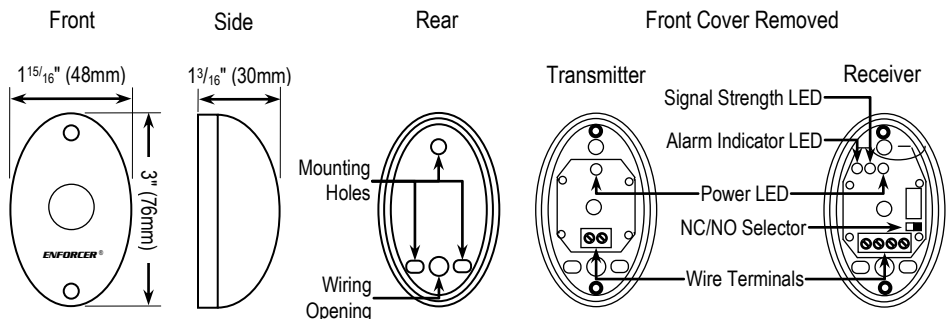

---

## Sample Installation:

**NOTE:** Do not mount the sensor where it is exposed to direct sunlight to prevent damage to it.

**NOTE:** For best operation, there should be a minimum of 40 inches (1 meter) between the transmitter and receiver.

1. Find a location where the transmitter and receiver can be installed facing each other.
2. Ideally, mount the sensor at least 8" (20 cm) above the floor. However, the actual mounting height will depend on the application.
3. Test the sensor before mounting. Connect power to the transmitter and receiver, and hold them in the desired location by hand. Break the beam between them by walking through or slowly waving a hand through the beam. Adjust the location until the device operates properly.
4. Disconnect power.
5. With a pencil, lightly trace around the transmitter and receiver on the wall to show where they will be mounted.
6. Take the covers off the transmitter and receiver. Hold the bases against the wall in the areas traced, then use a pencil to mark the three holes in each base for mounting screws.
  - a. Wood or metal wall: Use a drill bit to drill a starter hole for each of the three mounting screw holes in each base. Then screw the mounting screws into the three holes.
  - b. Dry wall: Use a drill bit to drill a hole just barely large enough to insert the plastic wall anchors. Then screw the mounting screws through the base into the plastic wall anchors.
7. Ensure that the NO/NC jumper switch is correct for the device to be activated (default is N.C.).
8. Reconnect power, and connect the appropriate wires for the device to be activated to the receiver wire terminals.
9. Replace the covers and then re-test the sensor.

---

## Wiring Diagram:

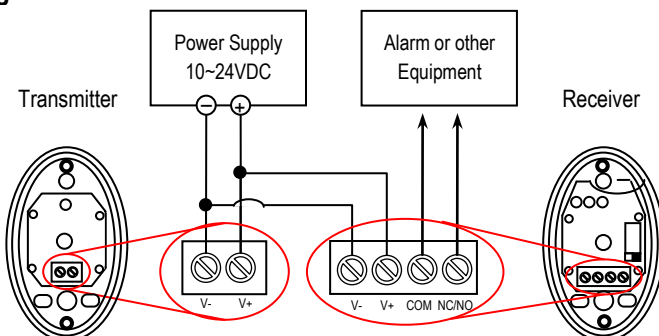

# WIRING SCHEMATIC TO CONNECT E-PBD-SO50 TO E-2D/5D/16D

FOR E-2D

VIEW OF TERMINALS ON E-2D

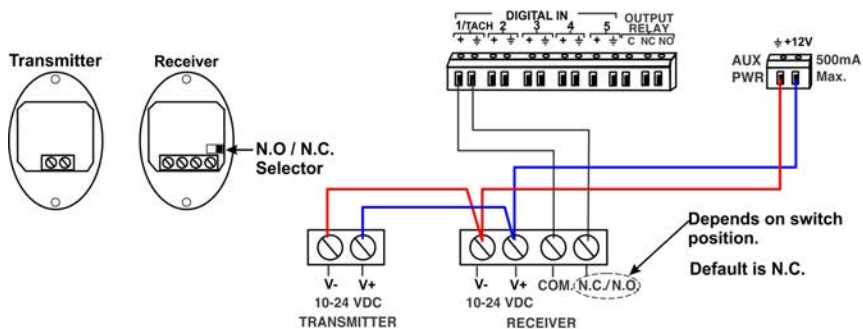

TERMINAL BLOCKS OF E-PBD-SO50

FOR E-5D

VIEW OF TERMINALS ON E-5D

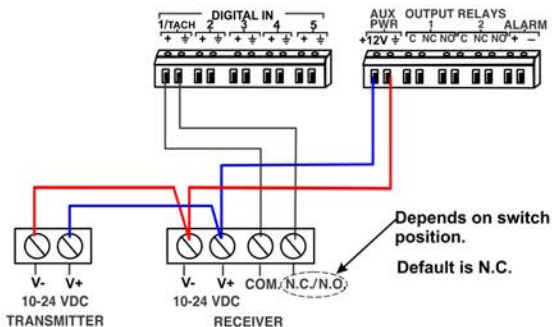

TERMINAL BLOCKS OF E-PBD-SO50

FOR E-16D

Note: On the E-16D, any Digital In can be used to power an E-PBD-SO50.

VIEW OF TERMINALS ON E-16D

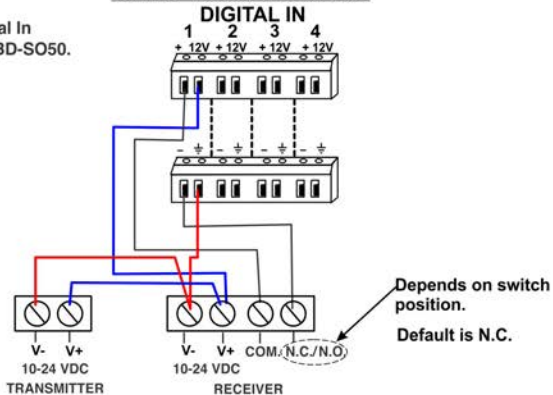

TERMINAL BLOCKS OF E-PBD-SO50

---

## Troubleshooting:

---

Sensor does not detect the object	<ul style="list-style-type: none"><li>• Object may have a reflective surface which confuses the sensor. Try changing the angle of the sensor</li></ul>
Green power LED does not turn on	<ul style="list-style-type: none"><li>• Ensure that the power is connected</li></ul>
Yellow LED or Red LED does not turn off	<ul style="list-style-type: none"><li>• Clean the transmitter and receiver sensors with a damp (not wet) cloth</li><li>• Readjust the alignment of the transmitter and receiver</li></ul>
Red LED lights when object is detected, but the output device is not activated	<ul style="list-style-type: none"><li>• Check the wiring between the receiver and the output device for continuity</li></ul>

---